



9/00439
2-way full set
(using stainless centre
case, 9/00438, standard
end latches and links).

Single-sided 'FS'
keys are standard



The 'Paddle' concept provides an attractive, fully self-contained lock/latch, which is flush fitting and simple to install

'PADDLES' 2-WAY MODELS

With these units the paddle case has an integral 2-way mechanism, allowing it to be used for slam systems on larger doors, fitted vertically or horizontally. Full choice of finish options, with several types of end latches. Order as centre units only, or full sets as illustrated.

! All-stainless mechanism, heavy duty slide and locking cam, mirror finish on case/flap and no sharp edges. Moulded gasket supplied.

W Latches slam against sides of door frame or strikers, released by lifting paddle flap.

↕ Locking with key blocks flap and 2-way mechanism, but end latches are still free to operate using 'free movement' aperture in link bar (as illustrated).

M Stainless models have pierced rim as shown or internal welded studs, with moulded gasket. Mild steel models normally have plain rim (for weld-on mounting). Link bars held by split pin on pillar rivets.

Key 'FS' as standard, optionally 'FT', '92', or 'DLP' key types. Non-locking models.

Wrench Polished stainless steel, or mild steel, bright zinc-plated. Optionally, black powder-coated finish.

M With stainless models, all steel components made in Grade 304. With mild steel models, case and flap made in CR4, zinc-plated, with diecast cylinder and locking cam.

? - Moulded weathershield on (round) lock
- Alternative end latches
- Centre case with shaped 'grip'

ORDERING CODE

Stainless models with pierced rim (& gasket)

- 9/00438** 2-way paddle centre, locking
- 9/00438/01** 2-way paddle centre, FS 880
- 9/00439** 2-way paddle system, locking
- 9/00439/01** 2-way paddle system, FS 880
- 9/00417** 2-way paddle centre, non-locking
- 9/00437** 2-way paddle system, non-locking

Mild Steel models with plain rim, (& gasket)

- 9/00409** 2-way paddle centre, locking
- 9/00409/01** 2-way paddle centre, FS 880
- 9/00429** 2-way paddle system, locking
- 9/00429/01** 2-way paddle system, FS 880
- 9/00416** 2-way paddle centre, non-locking
- 9/00436** 2-way paddle system, non-locking

Consult sales office for 'blind-mount' models

'Blind-mounting' models

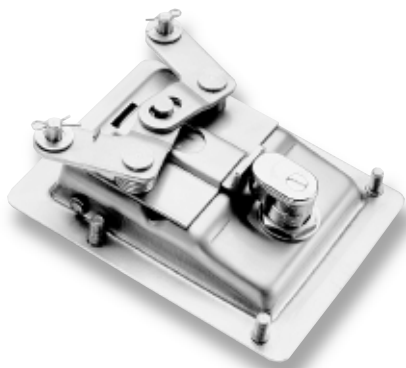

'Blind mounting' models have four studs (M6x15mm) welded on inside flanges. This option is available on all paddles. Consult engineering drawing for position of studs (not same as holes).

SPECIFICATION

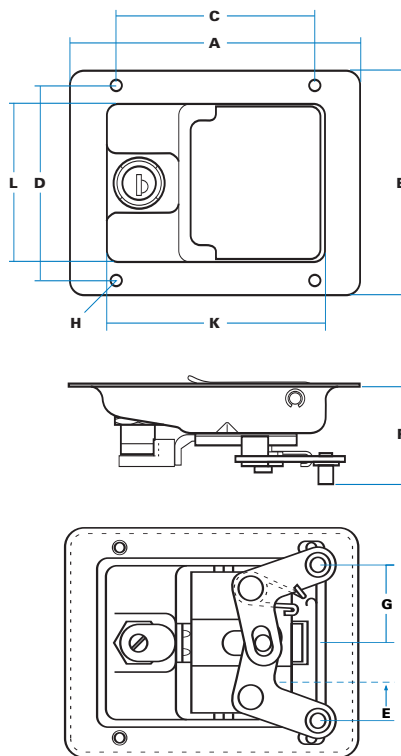

E	'Travel' of link point	15 mm
F	Depth of link point	37 mm
G	Location of link point	47 mm

Note : 'F' can be reduced to 30mm by mounting pillars on inside face of levers.



Standard linkage bar 3/12497 (915 mm) used for 2-way slam system. Piercing allows 'quick fit' attachment of latches and free movement when centre is locked.