

9/00359
Right-hand

'TRAIL-PLATE' INSIDE RELEASE & HANDLES

Highly versatile units which allow door latches to be operated from a handle some distance away. Particularly useful on wide doors, trucks, and off-road vehicles.

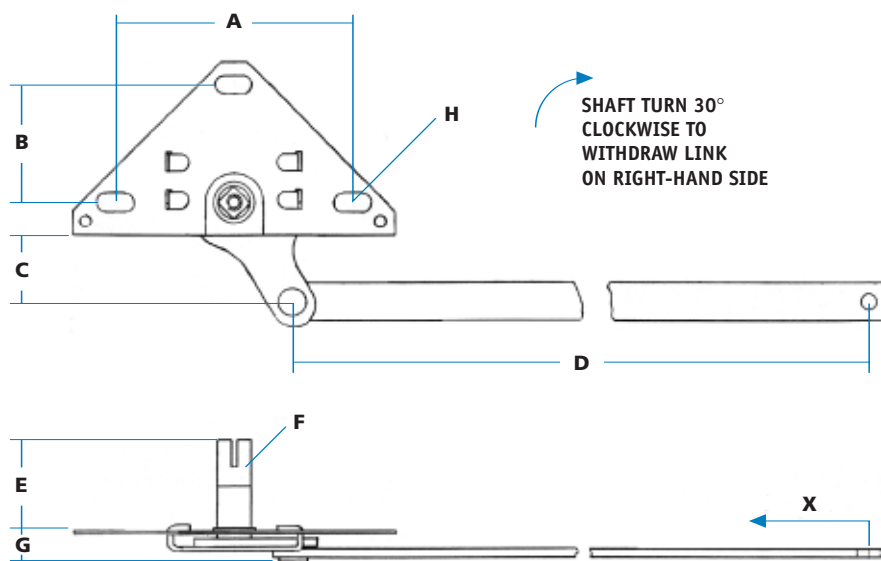

! Units are 'handed' LH/RH with a 8 mm-square (5/16") spindle, aligned at 45° to vertical, with provision for safety locking (see below).

W Pull inside handle as shown, withdrawing link bar and operating latch. Push in other direction to lock handle into a détente.

↕ Install as shown to achieve correct movement on each side of vehicle. Units may be inverted to reverse movement of link bar.

≡ Semi-plant on, with slotted holes for adjustment, and normally covered with trim panel.

🔧 Yellow zinc-plated mechanism. Handles are chromium-plated.

? - Alternative spindles (length, alignment)
- Special link bars to order.

+ Use with inside handles shown, and with rotary latches (D18) or similar.

ORDERING CODE

9/00359 Inside release, RH

9/00360 Inside release, LH

SPECIFICATION

A Length (between centres)	80 mm
B Width (between centres)	40 mm
C Projection	22.5 mm
D Link bar	380 mm
E Spindle height	32 mm
F Spindle tapped	15 mm x 10-32 UNF
G Rear projection	10 mm
H Hole sizes	6 x 13 mm
X Travel of latch release	25 mm

